

STARTING A PRINT

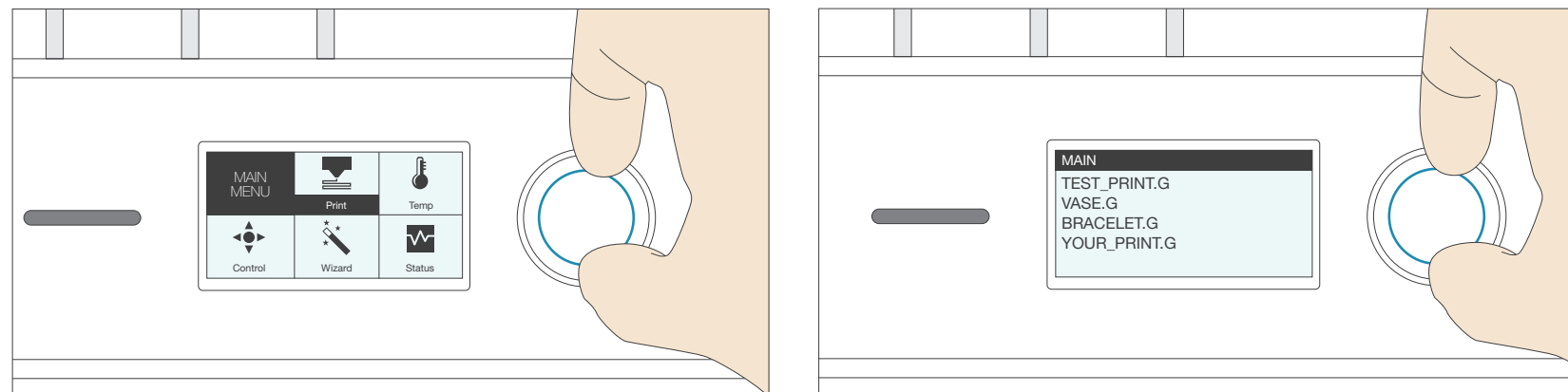

- 1 Insert your SD card into the slot to the left of the screen. Use the dial to select Print on the main menu.
- 2 Scroll down to the file you want to print and push the dial in to start the print.

Whenever you begin a print, always check that the first layer of the print is properly stuck onto the blue painter's tape. A properly leveled bed should have the extruded filament a bit squished and shouldn't pop off the bed easily. While the printer is performing the skirt nozzle purge, observe the deposited filament and make micro-adjustments with the thumb-screws if necessary.

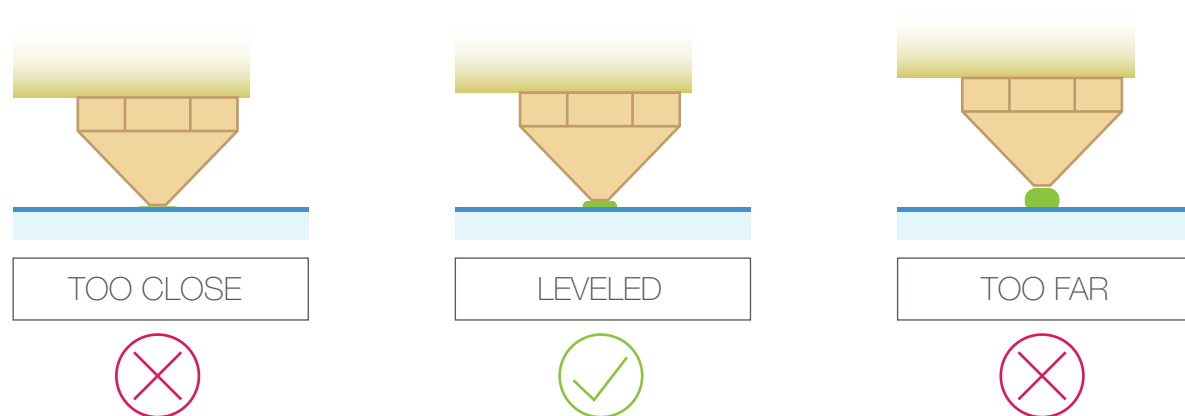

- !** Bed Leveling Tip! The on-screen instructions will guide you through leveling your bed at three different points. For proper calibration, slide a piece of construction paper under the hotend at each of the three points. Tighten/loosen the leveling screws to ensure a slight drag on the construction paper. Turn the screws clockwise to raise the bed and counterclockwise to lower the bed.

TECHNICAL SUPPORT

For technical assistance, please contact your authorized VariQuest dealer or the VariQuest Technical Support team:

- Email: techsupport@variquest.com
- Phone: 1-800-328-0585



Use a box cutter to trim along the taped edges and peel back the outer box flaps.



The Trifecta™ 800 3D Printer can be too heavy to lift out of the box by yourself. Ask for help to prevent injury or damages to the printer.

- 1 Open shipping box and remove the compartment lid.

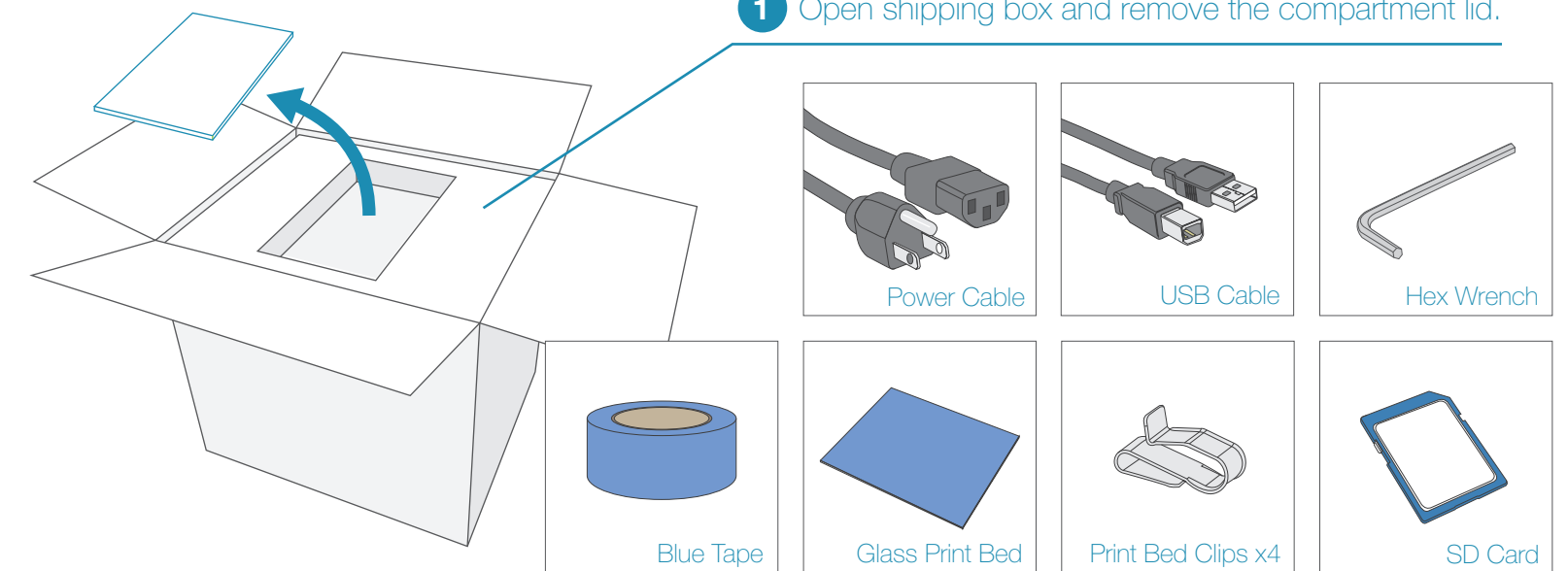

- 2 Remove printer accessories from the compartment.



- 3 Remove foam bracket and take out the printer and filament.

- 5 Place the printer on a firm flat surface.

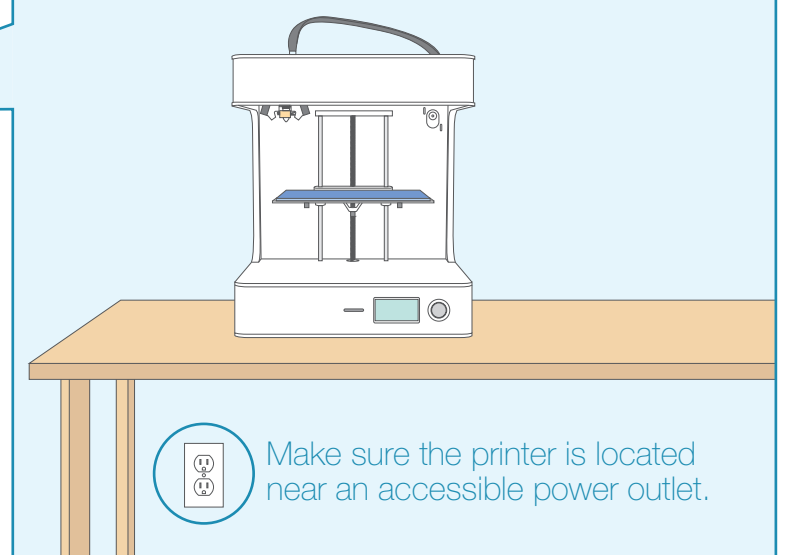

- !** Place the Trifecta™ 800 3D Printer and PLA Filament in a moisture-free and low dust environment.
- !** Store opened spools of filament in a sealed bag with a desiccant packet.

- 4 Remove the printer and filament from the box.

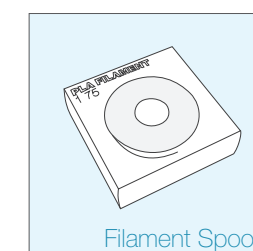
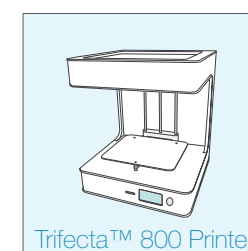

- 6** Remove the two gantry clips securing the extruder by pushing the tabs on each end of the clips.

- !** Store the removed clips and reuse when transporting the printer for shipping.

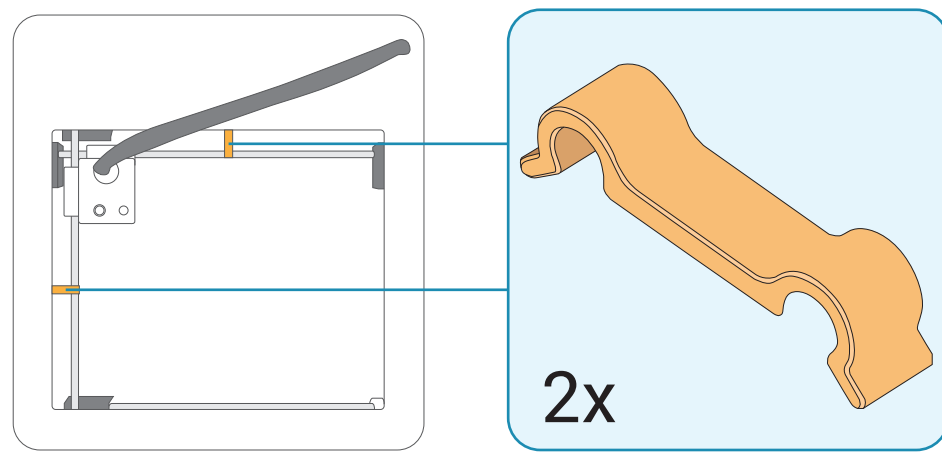

TURNING ON THE PRINTER

- 1 Make sure the power switch on the printer is in the Off position (O).
- 2 Insert the female end into the power socket located on the back of the printer.
- 3 Insert the male end of the power cord into an electrical socket.
- 4 Turn on the printer by flipping the power switch to the On position (I).

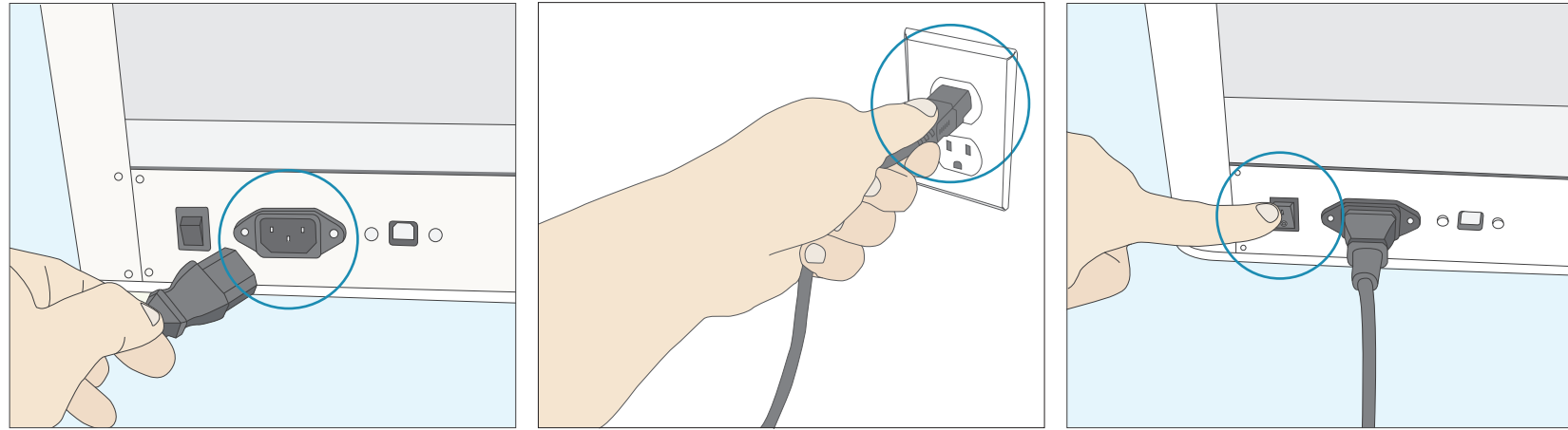

INSTALLING THE FILAMENT

- 1** Extend the filament guide tube from the retracted position.

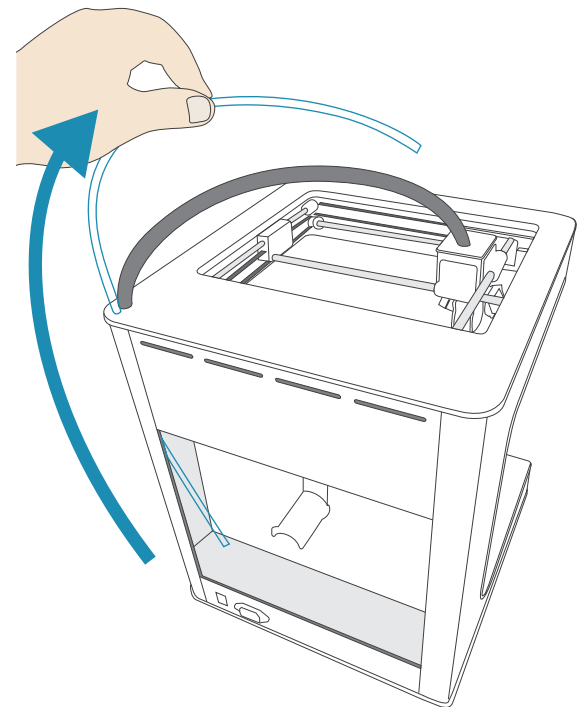

- 2** Remove the filament spool from the packaging and place it on the spool holder.

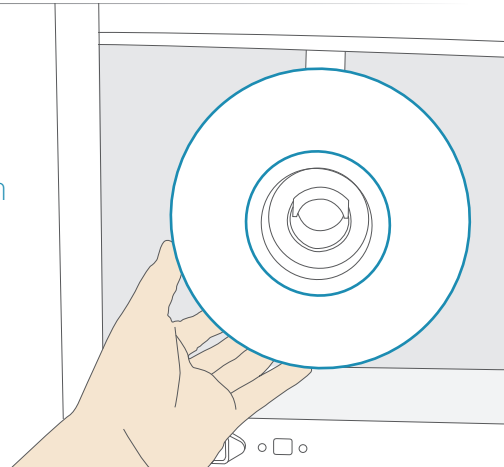

- 3** Take the end of the filament from the spool and insert it into the guide tube.

- !** Make sure the spool will spin clockwise as the filament feeds into the guide tube.

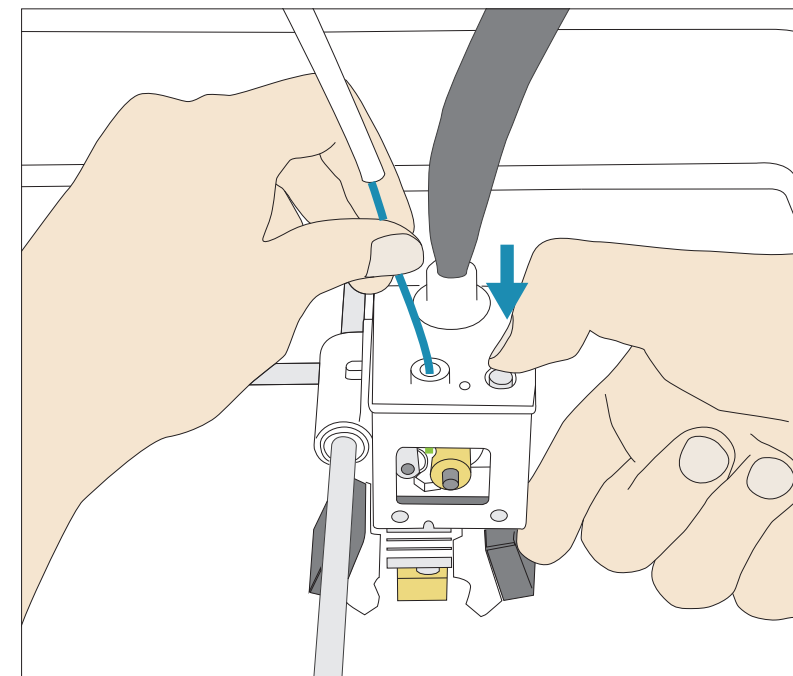
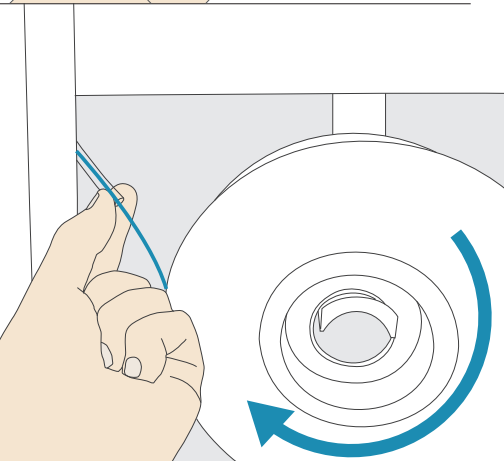

- 4** Thread the filament through the guide tube. Push the tensioner button down to insert the filament through the drive gear and into the hotend.

- !** Cut the tip of the filament at an angle if you are having trouble feeding the filament into the hotend.

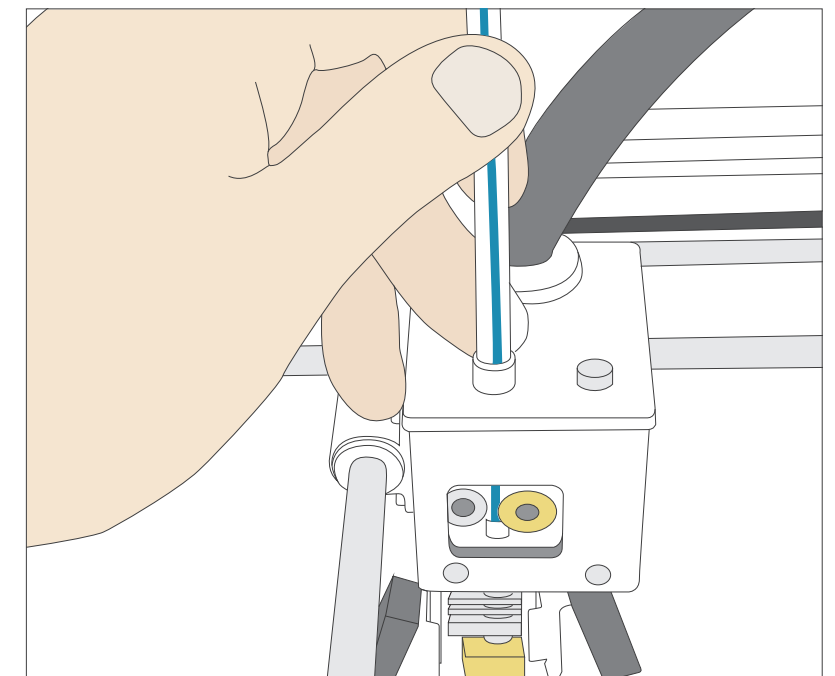

- 5** Once the filament is inserted all the way down into the hotend, insert the guide tube into the top of the extruder cap.

INSTALLING THE PRINT BED

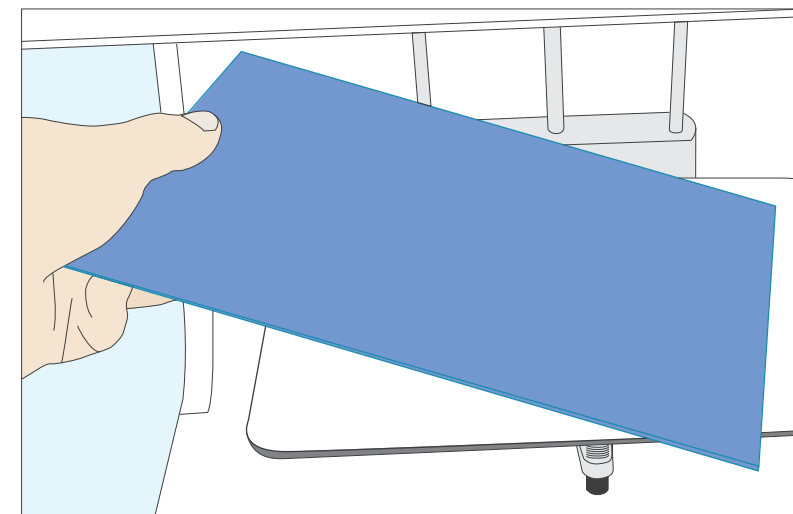

- 1** Place the glass print surface onto the bed with the blue painter's tape side facing upward. The tape will act as an adhesion material for the plastic.

- !** Replace any worn or damaged blue painter's tape as needed to ensure that your prints stick properly during the printing process.

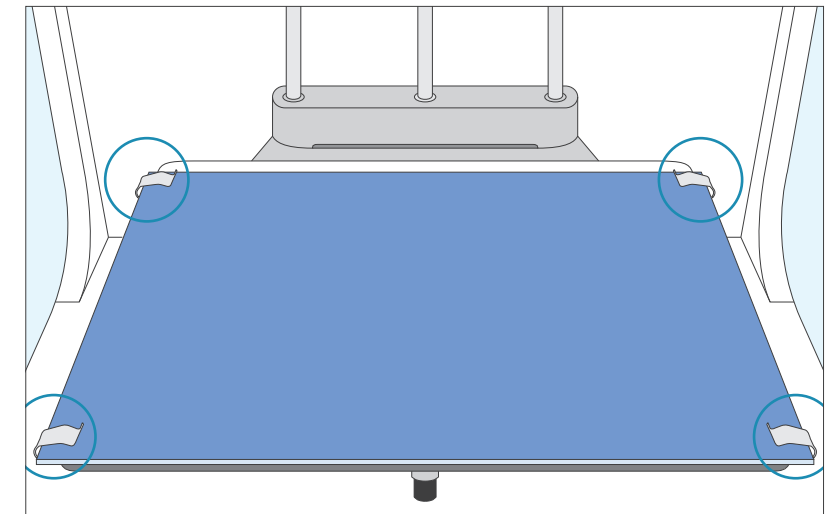

- 2** With the clips provided in the kit, slide each clip on to pinch the bed platform and glass print surface together. Attach the clips onto the bed as shown.

STARTING THE PRINT BED CALIBRATION

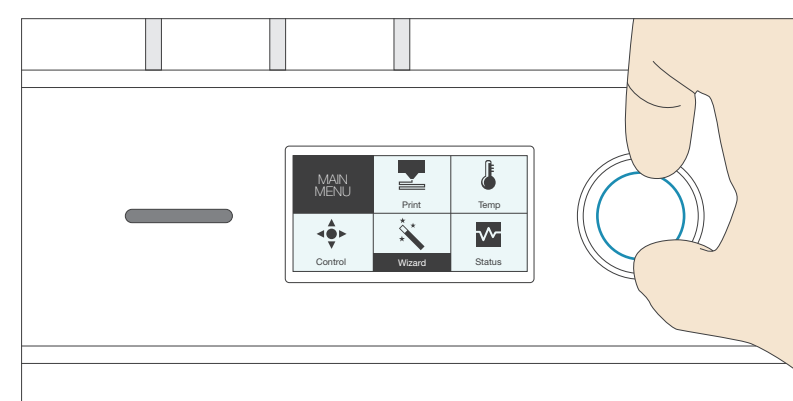

- 1** From the main menu, turn the dial to scroll to Wizard. Push the dial in to select.

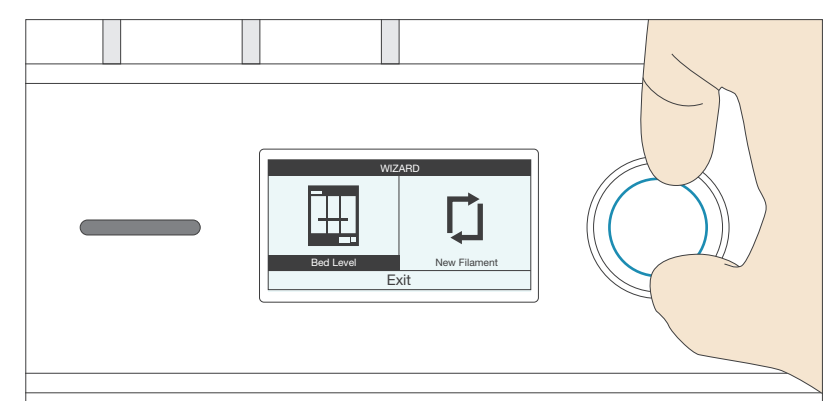

- 2** Select the Bed Level option and follow the on-screen instructions to level the print bed.