

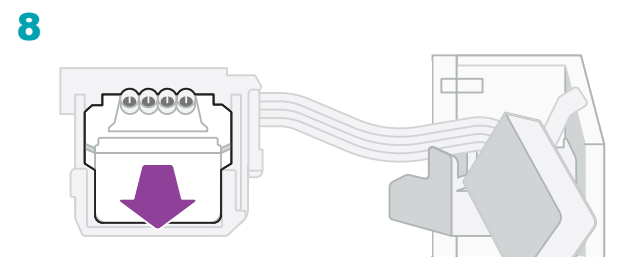

Perfecta® Q Series Poster Design System Printhead Installation Guide

Compatible with the Perfecta® Q36

- 1** » On the main menu, select 
» Select **Image Quality Maintenance > Replace Printhead**

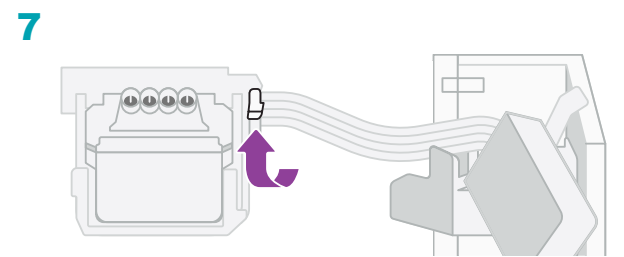
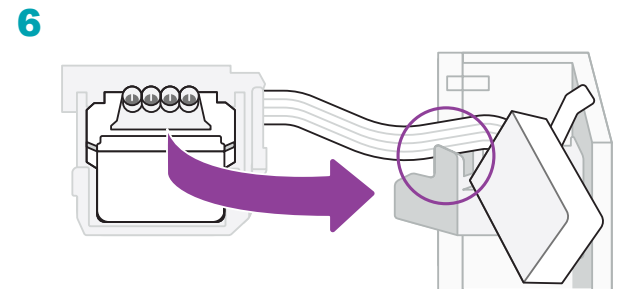
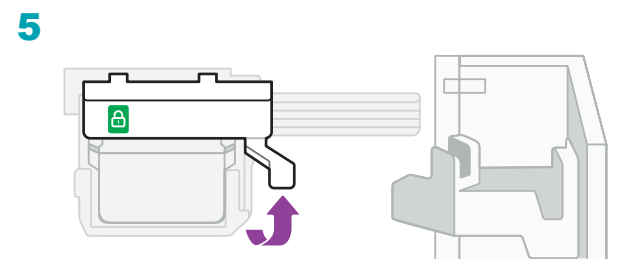
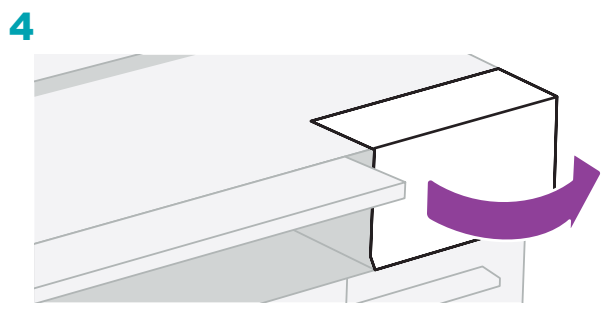
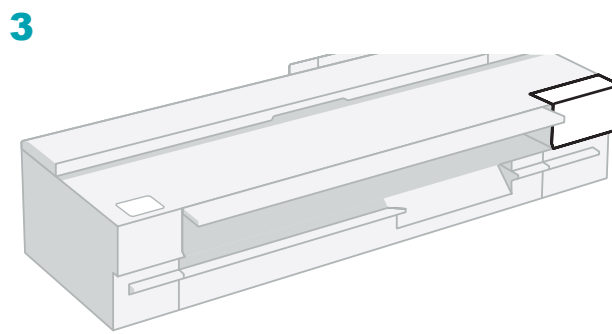
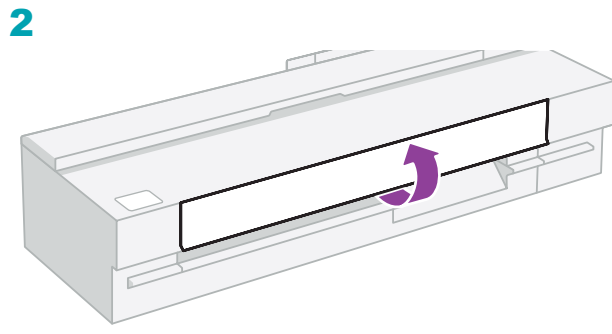
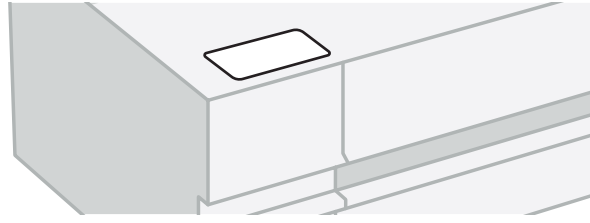

9

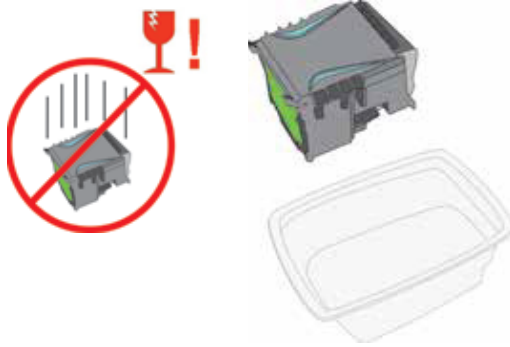

13

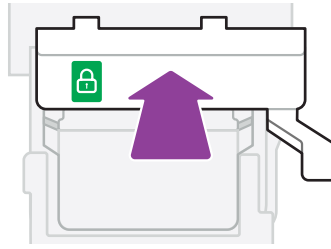

14

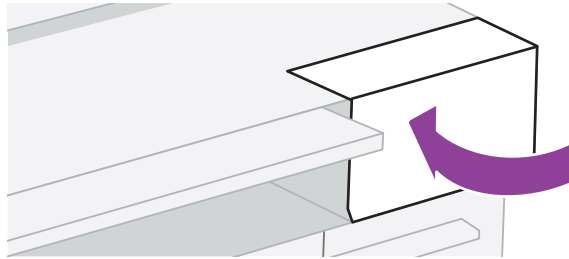

15

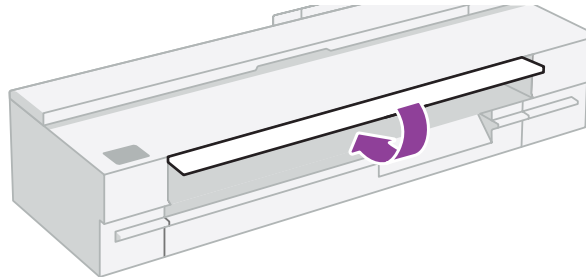

10

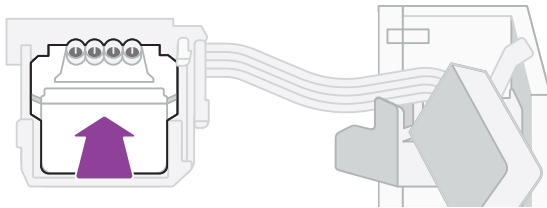

11

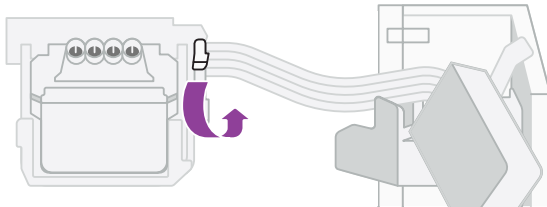

12

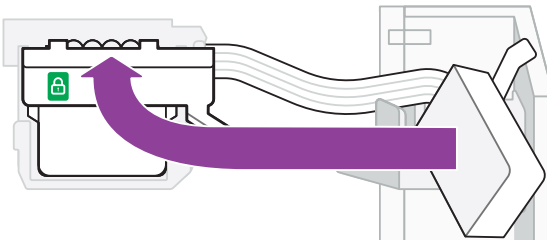

Technical Information

Not licensed for products unauthorized by Varitronics.

Varitronics may change product designs, features or specifications at any time.

CAUTION!

Keep out of reach of children. Avoid contact with eyes. Ink may be harmful if swallowed. Additional information can be obtained from <https://resources.variquest.com> or on request.

This product has a limited one year warranty from date of installation. If product is defective, contact your authorized VariQuest® dealer before the end of the warranty date. Warranty does not cover empty or refilled products, or products that have been tampered with or misused. For complete warranty details please contact Technical Support.

Technical Support

For technical assistance, please contact your authorized VariQuest dealer or the VariQuest Technical Support team:

- **Email:** techsupport@variquest.com
- **Phone:** 1-800-328-0585

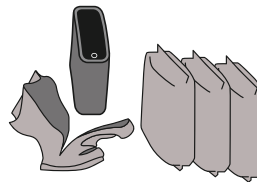

If ink cartridge replacement is required, save used ones for later use.

